

ZT1218D 3/16" (4.8MM) Air Hydraulic Riveter W/DIGITAL MODULE

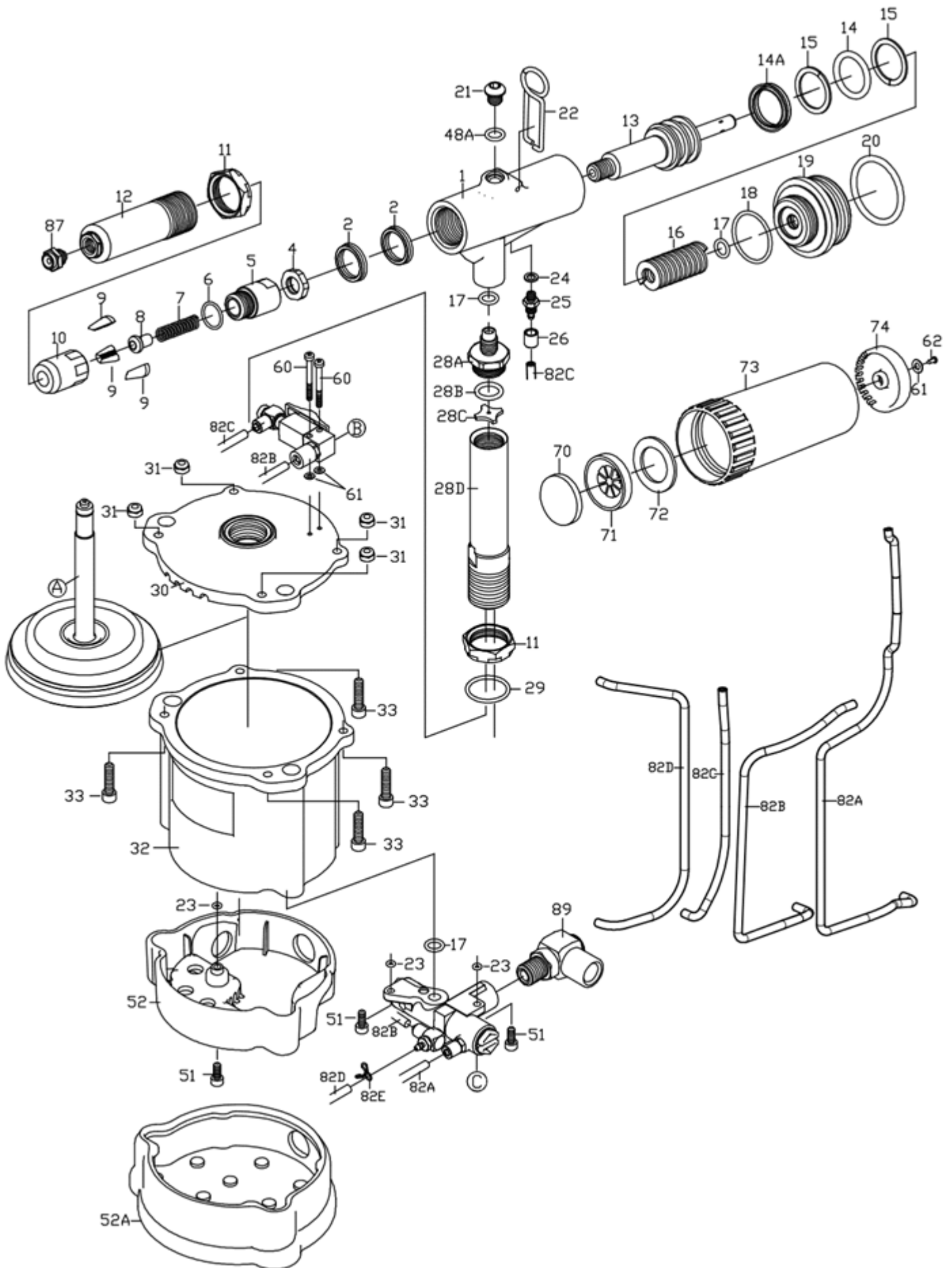

Ⓐ ASS'Y

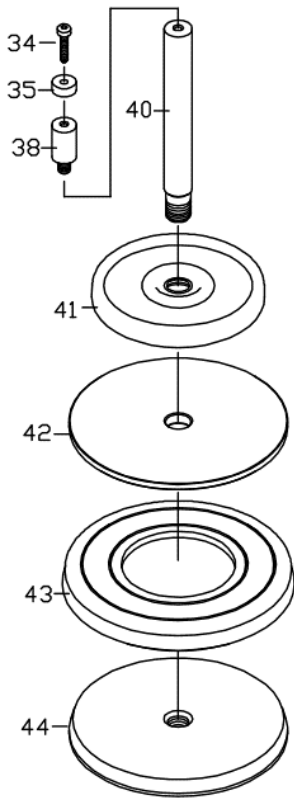

Ⓑ ASS'Y

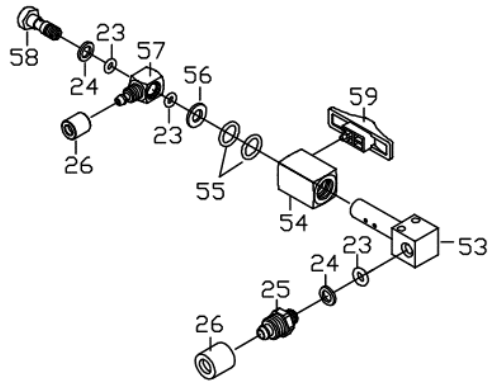

Ⓒ ASS'Y

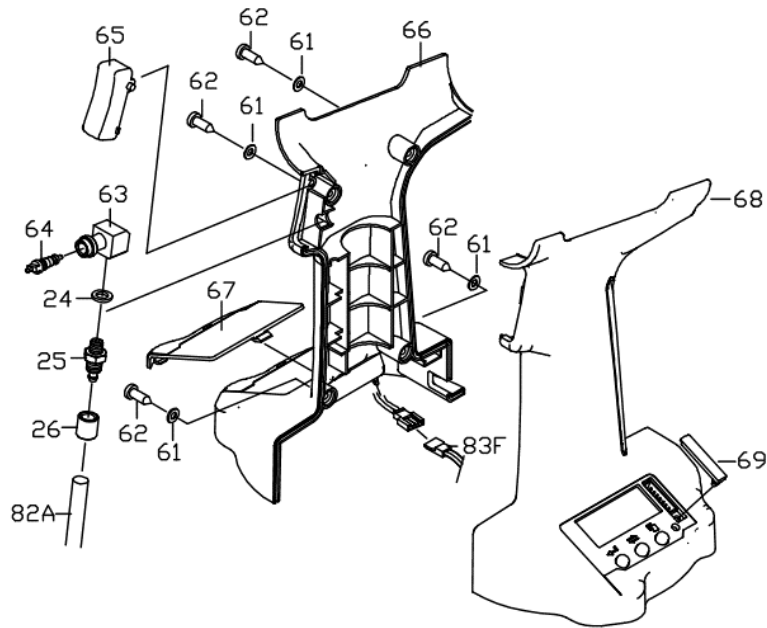
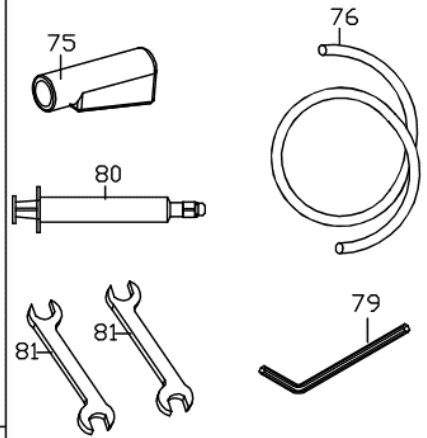
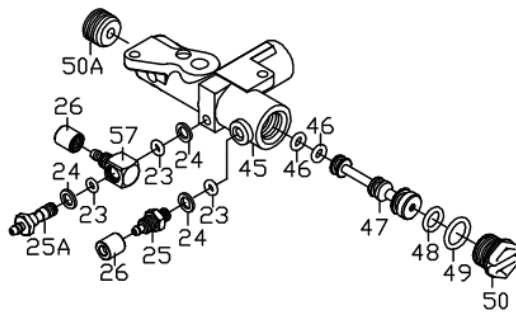

Digital Module Assembly

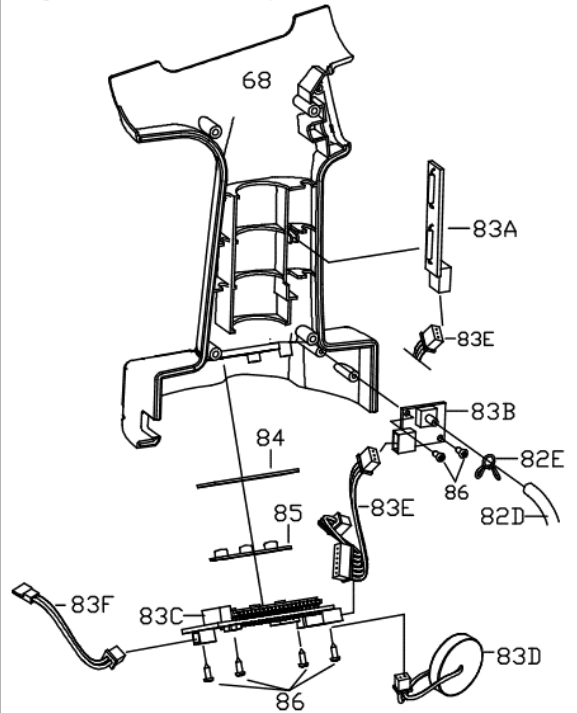

ZT1218D 1/4" (6.4MM) Air Hydraulic Riveter W/DIGITAL MODULE

TECHNICAL DATA	Traction Power	lbf(kgf)	: 2533(1150)
	Stroke Length	mm	: 18
	Net Weight	lbs(kgs)	: 4.2(1.9)
	Nosepieces Equipped	inch(mm)	: 1/4(6.4)
	Max. Capacity		: Max. 1/4"(6.4mm)blind rivets in steel/steel

PARTS LIST

Index	Part #	Description	Index	Part #	Description
1.	922101R	Hydraulic Section	51.	HC00407010	Set Screw (3)
*2.	MS1621	Oil Seal (2)	52.	922402	Base
4.	214306	Nut	52A.	922404	Rubber Boot
5.	214305	Jaw Housing Coupler	53.	922701	Vacuum Valve
6.	OR1417	O-RING	54.	922702	Sleeve
7.	922308	Spring	55.	OR0811	O-RING (2)
8.	922302	Jaw Pusher	56.	PW0510	Washer
*9.	819313	Jaw (3)	57.	612712	Swivel (2)
10.	612324A	Jaw Hosing	58.	612713	Socket
11.	918106	Lock Nut (2)	59.	922703	Vacuum Switch
12.	612105	Head	60.	HC00305020	Set Screw (2)
13.	922301	Hydraulic Plunger	61.	PW0306	Washer (7)
*14.	OR2229	O-RING	62.	ST0310	Screw (5)
*14A.	MS2229	Oil Seal	63.	107602	Valve Body
*15.	BR2229	Back-Up Ring (2)	64.	107601	Bleeding Valve
16.	922309	Return Spring	65.	107201R	Trigger
17.	OR0812	O-RING (3)	66.	922107RVE	Plastic Grip-Right
18.	OR2832	O-RING	67.	922107C	Battery Cap
19.	922102	Rear Gland	68.	922107LVE	Plastic Grip-Left
20.	OR3542	O-RING	69.	202E09	Dust Cover
21.	HR00812508	Set Screw	70.	919904	Silencer
22.	258801	Hanger	71.	919903	Muffler Seat
23.	OR0306	O-RING (9)	72.	919905	Silencer
24.	612714	Washer (7)	73.	919901	Mandrel Collector
25.	612717	Socket (4)	74.	919906	Muffler Cap
25A.	612713A	Socket	75.	612901	Deflector
26.	612711	Cap (6)	76.	612902	PU Tube (OPT.)
28A.	9221082	Hydraulic Tube Connector-B	77.	612904	Multi-Wrench (A)
28B.	OR1417	O-RING	78.	918905	Multi-Wrench (B)
28C.	8211012	Hydraulic Tube Washer	79.	314755	5mm Hex. Wrench
28D.	2181081	Hydraulic Tube Connector-A	80.	922901	Oiler
29.	OR2025	O-RING	81.	144905	17x19 Wrench (2)
30.	922401R	Upper Cover	82A.	922704A	2.5x4 PU Hose(Black)
31.	NN005080B	Nut (4)	82B.	922704B	2.5x4 PU Hose(Orange)
32.	922403R	Air Cylinder Body	82C.	922704C	2.5x4 PU Hose(Orange)
33.	HC00508020	Set Screw (4)	82D.	922704D	2.5x4 PU Hose(Black)
34.	TC00808010S	Set Screw	82E.	258804	4mm Hose Loop (2)
35.	258504	Magnet	83A.	202E01	Counter Sensor
*36.	MS1317	Oil Seal (2)	83B.	202E02	Pressure Sensor
38.	9225112	Magnet Seat	83C.	202E03	Digital Display
40.	218501	Plunger Rod	83D.	202E04	Lithium Battery
41.	202505	Bumper Ring	83E.	202E05	Signal Terminal
42.	107503	Front Head Disc	83F.	202E06B	Power Cable - Display Terminal
43.	819502	Packing Ring	84.	202E07	Display
44.	107502	Lower Plate	85.	202E08R	Button
45.	919211	Valve Case	86.	ST0206	Screw (6)
*46.	OR0408AS	O-RING (2)	87.	612705	Nose Piece 5/32"(4.0mm)
47.	919202A	Valve Stem		612706	Nose Piece 3/16"(4.8mm)
*48.	OR0711	O-RING		612746	Monobolt 3/16"(4.8mm)
48A.	OR0711A	O-RING		612708	Nose Piece 1/4"(6.4mm)
*49.	OR1014	O-RING	89.	92L2	Air Inlet Assembly
50.	107409	Inlet Plug	90.	0922SK	Service Kit (opt.)
50A.	922409	Socket Screw			(No.02.09.14.14.A15.36.46.48.48A.49)

Maintenance Schedule

Frequency	Action
Daily after work or every 5,000 cycles	Lubricate tool through air inlet . Clean inside of Head
Jaws will not grip rivet stem or Every 20,000 cycles	Replace new Jaws
When oil leakage occurs or every 50,000 cycles	Replace O-Rings and Back-Up-Rings in Hydraulic Section and Hydraulic Tube .
every 100,000 cycles	Replace Packing Ring in Air Cylinder

Troubleshooting

Symptom	Diagnosis	Remedy
Rivet cannot be set by a single pull	<ol style="list-style-type: none"> 1. Low working air pressure 2. Tool requires re-priming 3. Worn Jaws or dirt in Jaws 4. Broken Jaws 	<ol style="list-style-type: none"> 1. Check air pressure at the tool. 2. Priming the tool correctly according to the instruction 3. Replace the Jaws
The tool can't do suction	The Suction Switch didn't open	Turn on the Suction Switch .
Jaws will not grip rivet mandrel	<ol style="list-style-type: none"> 1. Worn Jaws or build up of dirt on Jaws 2. Jaw Housing loose 3. Weakened Jaw Pusher Spring 	<ol style="list-style-type: none"> 1. Clean before replace new Jaws 2. Tighten Jaw Housing, Jaw Housing Coupler and Nut 3. Replace new Jaw Pusher Spring
Broken rivet mandrel can't be released by Jaws	<ol style="list-style-type: none"> 1. Dirty Jaws and Jaw Housing 2. Weakened Jaw Pusher Spring 3. Hydraulic oil over primed. 	<ol style="list-style-type: none"> 1. Clean and re-lubricate 2. Replace Jaw Pusher Spring 3. Remove Plug Screw and O-Ring, let it spill till stop by itself
Broken rivet mandrel jammed inside the Head	<ol style="list-style-type: none"> 1. Damaged Jaws 2. Damaged or dirty Jaw Pusher 	<ol style="list-style-type: none"> 1. Replace Jaws 2. Replace or clean Jaw Pusher
The suction force is not strong enough to suck broken mandrel	<ol style="list-style-type: none"> 1. Low air pressure 2. Air leakage inside Suction Switch 	<ol style="list-style-type: none"> 1. Check and regulate proper air pressure 2. Check if exhaust air is stuck at rear end of Collector 3. Check and replace O-Rings
Digital monitor no display or show "Low"	Low battery power.	Replace new battery
Digital monitor show "Er1".	Inlet pressure is higher than 7.5kg/cm² .	Adjust the inlet pressure to the pressure below 7.5kg/cm² .
Digital monitor show "Er2".	<ol style="list-style-type: none"> 1. Oil leaking causes insufficient hydraulic oil 2. Improper assembly of the tool 	<ol style="list-style-type: none"> 1. Check the cause of leakage and replace seals if necessary 2. Re-prime hydraulic oil.

Digital Module Operation

1. Digital monitor

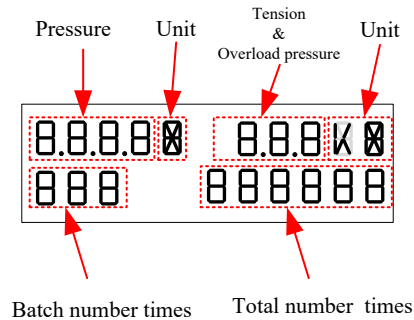

2. Button explanation

There are three button on the plastic grip-left.

 : **Module button**. The button is used to choose unit or 0~9 number.

 : **Shift button**. The button is used to select the mode.

 : **Enter button**. The button is used to confirm setting.

3. Turn on & turn off the monitor

Turn on : Push  button or the tool is working.

Turn off : No actuating the tool within 30 seconds, the monitor will be shut down automatically

4. Unit Selection

a. Push  button 3 seconds. Enter mould function, the monitor begins to flash.



b. Push  button. Pressure and **pulling force** display begins to flash.

c. Push  button. Enter **Unit** choose mode, Air Pressure and **pulling force** unit display begins to flash.



d. Push  button. Change unit.



Push  button again. Change unit.

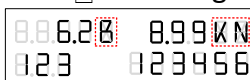

Push  button again. Change unit.



e. Push  button. Finish **Unit** setting. The monitor stop flashing.

Table 1 below is **Unit** selection of **Air Pressure** and **Pulling Force**.

Table 1. Unit displays

	Air Pressure unit	display	Pulling Force unit	display
ISO	Kg/Cm ²	K	KgF	K
ISO	MPa	M	NF	N
Newton	Bar	B	NF	N
ISS	Psi	P	LbF	B

5. Setting batch number

- a. Push **←** button 3 seconds. Enter module function, the monitor begins to flash.



8.8 6.3k 917k
123 23456

- b. Push **↔** button. The batch number display begins to flash.



8.8 6.3k 917k
123 23456

- c. Push **←** button. Enter batch number times function. The first number display begins to flash.

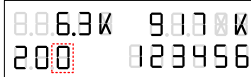

8.8 6.3k 917k
200 23456

- d. Push **□** button. Change number 0~9.

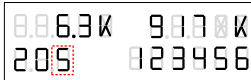

8.8 6.3k 917k
205 23456

- e. Push **↔** button. Change numbers'.

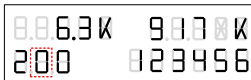

8.8 6.3k 917k
200 23456

- f. Push **←** button. Finish batch number setting. The monitor is stop flashing. Batch number display will show "0".

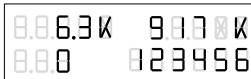

8.8 6.3k 917k
8.8 0 23456

- g. Push **←** button twice, the batch number display will show "0"

6. Error message :

- a. If working air pressure is over 7.5 kg/ cm²(107psi), the monitor will display "Er1".



8.8 7.5k Er1
8.8 0 23456

- b. Insufficient hydraulic oil inside Hydraulic Section, the monitor will display "Er2".



8.8 7.5k Er2
8.8 0 23456

- c. If battery is low power, the monitor will display "Low".

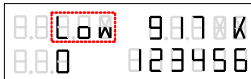

8.8 Low 917k
8.8 0 23456