

ZRD327DP 1/2" Air Reversible Drill

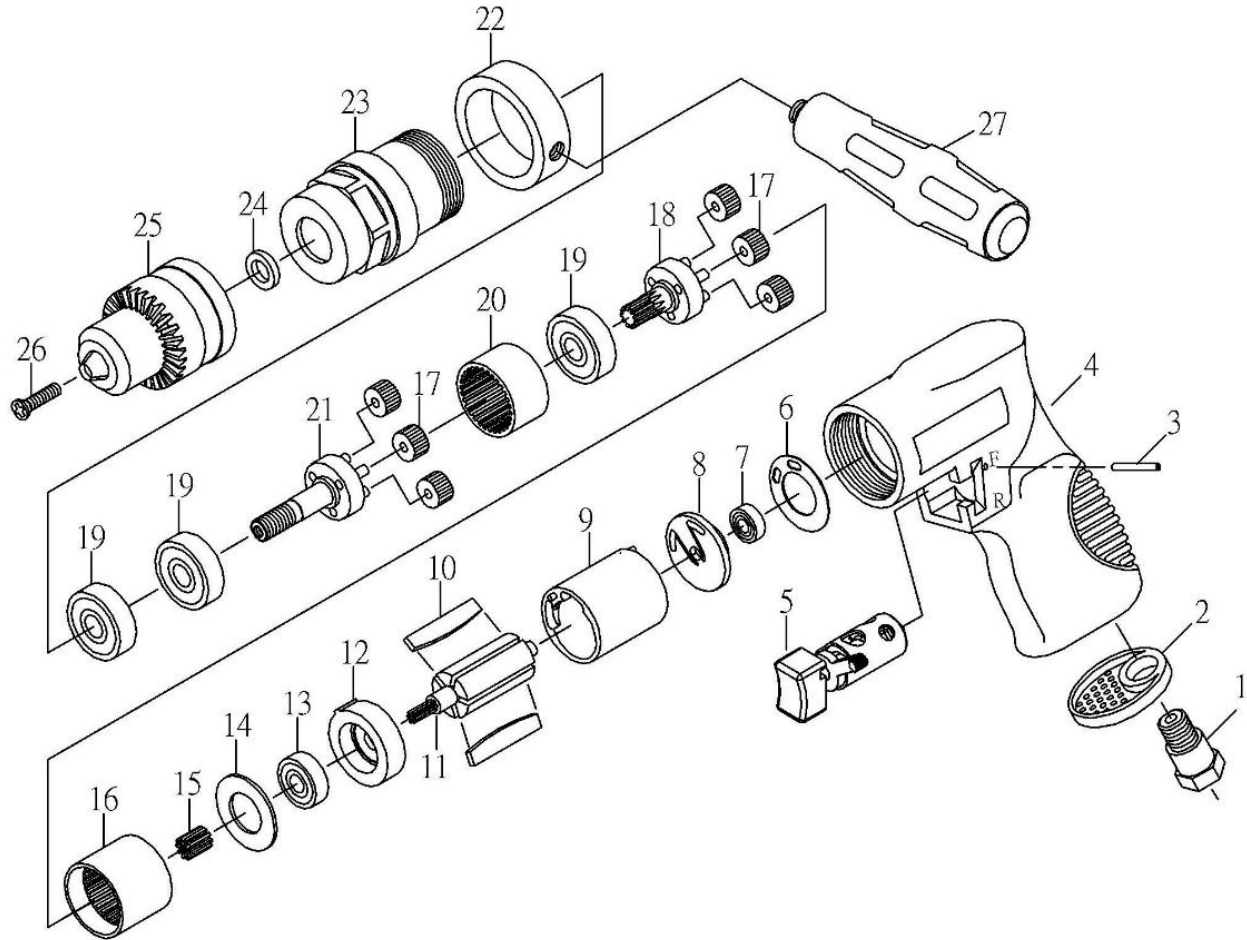

ZRD327DP 1/2" Air Reversible Drill

TECHNICAL

Chuck Size: 1/2(13) inch(mm)
 Spindle Thread: 3/8"-24
 Net Weight: 2.6(1.2)lbs(kgs)
 Length: 9(230)inch(mm)

Free Speed: 700rpm
 Air Inlet Size: 1/4 inch-NPT/PT
 Min. Hose Size: 3/8(10) inch(mm)
 Avg. Air Cons.: 4 cfm

DATA

PARTS LIST

Index	Part #	Description	Q'ty	Index	Part #	Description	Q'ty
1	ZRD327DP-01	AIR INLET	1	15	ZRD327DP-15	GEAR	1
2	ZRD327DP-02	EXHAUST SLEEVE	1	16	ZRD327DP-16	GEAR LINK	1
3	ZRD327DP-03	PIN	1	17	ZRD327DP-17	GEAR	6
4	ZRD327DP-04	HOUSING SET	1	18	ZRD327DP-18	GEAR PLATE	1
5	ZRD327DP-05	REVERSE LEVER SET	1	19	ZRD327DP-19	BEARING	3
6	ZRD327DP-06	PACKING	1	20	ZRD327DP-20	GEAR LINK	1
7	ZRD327DP-07	BEARING	1	21	ZRD327DP-21	SHAFT	1
8	ZRD327DP-08	REAR PLATE	1	22	ZRD327DP-22	HANDLE LINK	1
9	ZRD327DP-09	CYLINDER SET	1	23	ZRD327DP-23	CLAMP NUT	1
10	ZRD327DP-10	ROTOR BLADE	5	24	ZRD327DP-24	WASHER	1
11	ZRD327DP-11	ROTOR	1	25	ZRD327DP-25	1/2" CHUCK	1
12	ZRD327DP-12	FRONT PLATE	1	26	ZRD327DP-26	CHUCK SCREW	1
13	ZRD327DP-13	BEARING	1	27	ZRD327DP-27	HANDLE	1
14	ZRD327DP-14	WASHER	1				